

# Portable Evaporative Cooling System

## User's Manual



Manufactured by



HH TECHNOLOGIES

HH Technologies, Inc.  
1733 County Road 68  
Bremen, Alabama 35033  
256-287-7000

## Table of Contents

1	Warnings (Avertissements).....	3
2	Warranty.....	5
3	PolarCool Performance .....	6
3.1	Temperature Differential Readings .....	6
4	Unpacking, Preparation and Installation .....	7
4.1	18” PolarCool Caster Installation .....	7
4.2	Float Preparation.....	7
5	Start Up and Shut Down.....	8
5.1	Ventilation is Very Important.....	8
5.2	Normal Operation.....	8
5.3	Breaking in New Pads .....	9
5.4	Setting Up for Operation .....	9
5.5	Shut Down.....	9
6	Controls.....	10
6.1	18”, 24”, and 36” Variable Speed Control Panel.....	10
6.2	48” Single Speed Control Panel .....	11
7	PolarCool Pad Care and Maintenance.....	11
7.1	Breaking in New Pads .....	11
7.2	Frequency of Pad Replacement .....	11
7.3	Extending Pad Life .....	11
7.4	Cleaning or Replacing the Pads .....	12
8	Maintenance .....	13
8.1	Water Distribution (Spray Bar) .....	14
8.2	Flow Control Adjustment .....	14
8.3	Float Adjustment .....	15
8.4	Flushing the Reservoir.....	15
8.5	Cleaning the Pump Filter.....	16
8.6	Why Drain Water from the System?.....	16
8.7	Belt Inspection or Removal (48”Model Only).....	16
8.8	Winterization .....	17
9	Preventive Maintenance Requirements .....	17
10	Troubleshooting Guide.....	18
11	Replacement Parts List.....	19
12	Replacement Parts for Direct Drive – Variable Speed 18" PolarCool .....	20
13	Replacement Parts for Direct Drive – Variable Speed 24" PolarCool .....	21
14	Replacement Parts for Direct Drive Variable Speed 36” PolarCool .....	22
15	Replacement Parts for Belt Drive – Single Speed 48" PolarCool .....	23
16	PolarCool Wiring .....	24

## 1 Warnings (Avertissements)

### **Warning!**

Whenever Water And Electricity Are Combined In The Same Enclosed Environment  
The Possibility Of Electric Shock Exists.

Use Only On GFCI (Ground Fault Circuit Interrupt) Protected Receptacles.

Wiring And Connections Must Comply With All National And Local Electrical Codes.

Installation By Qualified Electrician Required!

### **Warning!**

Contact With Rotating Blades Could Result In Severe Injury Or Death.

“Caution” To Reduce The Risk Of A Fire Or Electrical Shock,  
Connect Directly To A 3-Pronged Grounding Receptacle.

Ensure The Electrical Outlet Provides The Required Ground Connection  
And Ground Fault Interruption Circuit Protection.

“Warning” To Reduce The Risk Of Fire Or Electrical Shock,  
Do Not Use With An Extension Cord.

### **Warning!**

Power Cord Must Be Disconnected Before Opening Lid For Any Purpose.  
Always Unplug This Product Before Installing Or Replacing Fuses.

### **Warning!**

Hazardous Rotating Fan Blade.

Do Not Place Fingers, Arms, Or Other Appendages Into The Path Of The Blade,  
Or Operate The Machine Without The Guards In Place.

Use Caution When Handling Sharp Metal.

 **Warning!**

Once Per Month, Inspect The Internals Of The PolarCool For Signs Of Electrical Insulation Breakdown. Check The Seal At The Motor, As Any Holes May Allow Water To Come In Contact With Open Electrical Circuits.

 **Warning!**

Do Not Run Cord Under Carpeting. Do Not Cover Cord With Throw Rugs, Runners, Or Similar Coverings. Do Not Route Cord Under Furniture Or Appliances. Arrange Cord Away From Traffic Area And Where It Will Not Be Tripped Over.

 **Warning!**

PolarCool Appliance Is Heavy!  
When Installing Wheels, Provide Adequate Support To Maintain Balance Of Appliance!

 **Warning!**

Do Not Place The Unit On A Slope Or Where The Unit Can Accidentally Fall Or Roll Into Water. The Lockable Wheels Provide Resistance To Movement Although Do Not Prevent Movement Or Turn-Over.

 **Caution!**

To Reduce The Risk Of Electric Shock,  
Connect Only To An Outlet Provided With A Ground Fault Circuit Interrupting Device.  
Do Not Operate Any Fan With A Damaged Cord Or Plug.  
Discard Fan Or Return To An Authorized Service Facility For Examination And/Or Repair.

## 2 Warranty

For three years from date of invoice, PolarCool warrants the motor and electrical components of its PolarCool Evaporative Cooling System that are found, upon examination by factory-authorized personnel, to be defective in material or workmanship.

PolarCool warrants its metal product housings for the full lifetime of the product to the extent they are found, upon examination by factory-authorized personnel, to be defective in material or workmanship. The Lifetime Warranty on product housings is void if the housing is found upon examination by PolarCool to have been misused, abused or otherwise tampered with by unqualified personnel. The Lifetime Warranty on product housings does not cover ordinary wear and tear and is non-transferrable.

If the original component parts, including product housings, develop a defect covered by this limited warranty within the applicable time periods described above, the same may be repaired or replaced at the option of PolarCool.

All transportation charges for shipment of the component parts that are submitted for replacement or repair under this warranty must be funded by the purchaser. No products are to be returned to the manufacturer, until there is an inspection and/or a return-goods authorization (RGA) number is issued.

All complaints should be directed first to the authorized distributor who sold the product. If satisfaction is not obtained or the name of the distributor is not known, write the manufacturer that appears below, directed to the attention of Customer Service Manager.

This warranty is void if: a) the Equipment and/or its component parts are found to have been misused, abused, repaired by or tampered with by unqualified personnel; b) any of the product's component parts have been replaced with parts that were not authorized PolarCool replacement parts; c) the product has been modified in any way (other than repairs made by qualified individuals with PolarCool replacement parts); d) the product has not been appropriately registered by its original purchaser; or e) the customer cannot show proof of purchase as the product's original owner.

This limited warranty is expressly in lieu of any and all representations and warranties expressed or implied, including any implied warranty of merchantability or fitness for a particular purpose. The remedy set forth in this limited warranty shall be the exclusive remedy available to any person. No person has authority to bind the manufacturer to any representation or warranty other than this listed warranty. The manufacturer shall not be liable for any consequential damages resulting from the use of our products or caused by any defect, failure or malfunction of our products (Some areas do not allow the exclusion or limitation of incidental or consequential damages, so the above limitation or exclusion may not apply to you.)

**Warrantor:**  
HH Technologies, Inc.  
1733 County Road 68  
Bremen, Al 35055  
256-287-7000



### 3 PolarCool Performance

The following table shows estimates of the performance of four sizes of the PolarCool Evaporative Cooling System. These values will vary depending on the particular installation and operating conditions. Both Variable Speed (VS) and Single Speed (SS) models are listed.

<b>PolarCool Model</b>	<b>Drive</b>	<b>Water Consumption Rates</b> (See Note 1)	<b>Power Consumption</b>	<b>Typical Air Movement Rates</b> (cubic feet per minute- See Note 2)
18" VS	Direct	5 gallons per hr.	5 amps @ 115v /60hz	3,000
24" VS	Direct	7 gallons per hr.	6 amps @ 115v /60hz	4,400
36" VS	Direct	12 gallons per hr.	10 amps @ 115v /60hz	10,000
48" SS	Belt	17 gallons per hr.	11 amps @ 230v /60hz	17,500

Note 1: This estimate is under 90+ degree conditions; cooler temperatures will result in less water usage.

Note 2: The cooling area is very dependent on the relative humidity, temperature, and the space being cooled.

#### 3.1 Temperature Differential Readings

The temperature drop from inlet to exit is very dependent on relative humidity and temperature. The higher the ambient temperature and the drier the air, the greater the drop. A temperature drop of 10 to 20 degrees is common.

## 4 Unpacking, Preparation and Installation



### Warning!

PolarCool Appliance Is Heavy!  
When Installing Wheels, Provide Adequate Support To Maintain Balance Of Appliance!

Carefully unpack the PolarCool from the shipping carton.

#### 4.1 18" PolarCool Caster Installation

1. Place wheel bracket against the caster support channel as shown in Diagram 4A.
2. Align holes and attach 5/16-18 x 3/4" carriage bolts, 5/16 washers, and 5/16-18 nylon-insert nuts as shown in Diagram 4A.
3. Repeat for all four casters.

Diagram 4A

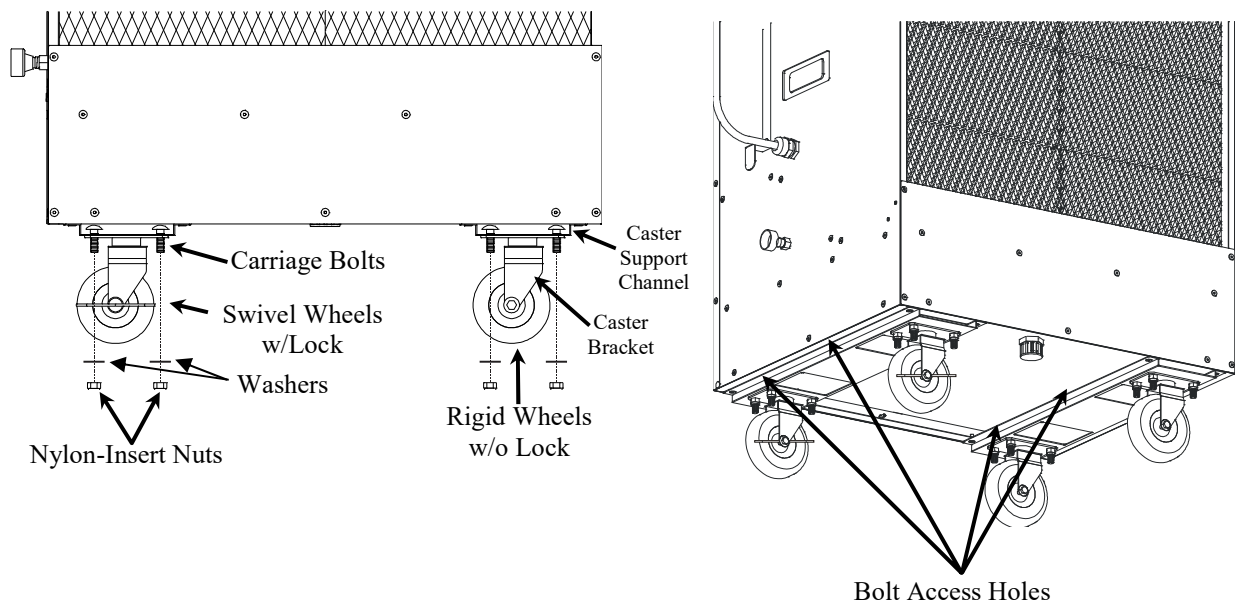

#### 4.2 Float Preparation

**IMPORTANT!**  
**Remove Tape From Float**  
**Before Operating!**

1. Lift Cover to gain access to pads as shown in Diagram 4B.
2. Tilt pads out of unit as shown.
3. Remove pads to access float.

Diagram 4B



PolarCool shown with Cover Open  
And Pad Tilted Forward



## Diagram 4C

Float Shown Ready For Operation

During shipment, the Float is securely taped to the pan of the PolarCool. Diagram 4C shows the Float with tape removed and ready for operation.

**CAUTION: Be careful not to bend the Float Arm when removing the tape!**

4. Apply hand pressure to hold float in place.
5. Carefully peel tape from float with other hand.

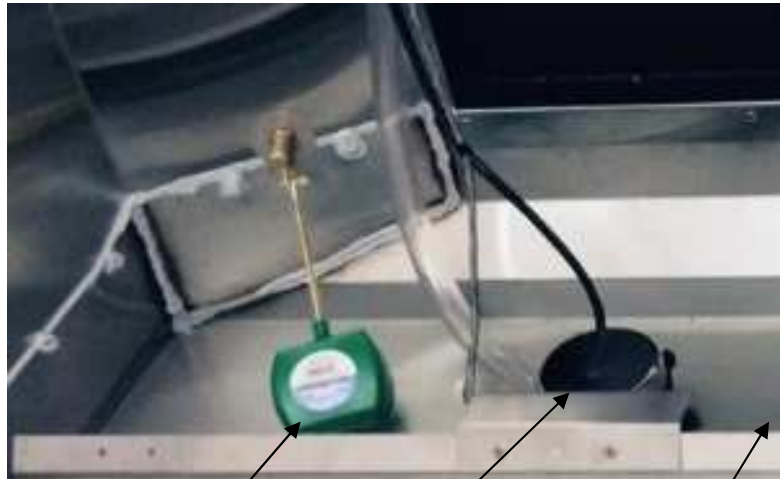

Float

Pump

Low Water Level Switch  
(Located Far Right Side)

6. Replace pads. Look for arrows on the side of pad as shown in Diagram 4D.

**NOTE: Ensure pads are replaced with up arrow pointed UP.**

## Diagram 4D

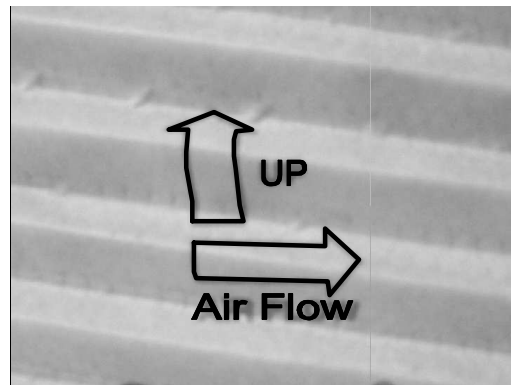

## 5 Start Up and Shut Down

### 5.1 Ventilation is Very Important

Fresh air is very important for proper operation of evaporative cooling. Ventilation can be provided by air flow from open windows and doors, or exhaust fans. Positioning the PolarCool intake close to an open door is a common way to assure fresh air. Evaporative cooling will not function properly in a closed environment.

### 5.2 Normal Operation

Under normal conditions, the pump should run constantly when air is being drawn through the pads. If outside conditions are not warm enough to run evaporative cooled air, an alternative is to run the fan with the pump off.

Dry the pads completely each night by turning off the pump and drawing air through the pads with the fan.



### 5.3 Breaking in New Pads

When pads are new, their slick surface will prevent the fast water absorption that will happen with older pads. For this reason, it is important that the first time new pads are used, to allow the pump to run for two or three hours. This will "soak-in" the pads, and allow faster start-up later.

After soaking new pads, turn off the pump, fan, and water supply, unplug the unit, and drain the reservoir. This eliminates chemical residues that have washed out of the new pads. See Section 7 for more information on Pad Care.

Foaming can occur with new pads. If excessive foaming is experienced, repeat the procedure described above two or three times to flush chemical residues from the pads. Reducing the water flow to the pads may also be helpful to reduce foaming.

**NOTE: Do not allow the pump to run without water in the reservoir.  
Without water, the pump may be damaged.**

### 5.4 Setting Up for Operation

#### **Warning!**

Do not place the unit on a slope or where the unit can accidentally fall or roll into water. The lockable wheels provide resistance to movement although do not prevent movement or turn-over.

#### **WARNING!**

Use only on GFCI (Ground Fault Circuit Interrupt) protected receptacles.

1. Connect water hose to inlet tap.

**NOTE: If desired, an optional customer supplied drain hose and cut-off valve can be attached to the drain pan outlet beneath the PolarCool.**

2. Check safety of electrical cords, and plug in unit.
3. Turn on water and fill the reservoir.
4. After the reservoir is filled, turn on the pump and let the water run for fifteen to twenty minutes before turning on fan. See Section 6 for Control Panel details.
5. Turn on fan and enjoy the cool air output.

### 5.5 Shut Down

When you are finished with the PolarCool, follow these steps for shutting down the unit:

1. Turn off pump.
2. Wait ten to fifteen minutes (This will dry the pad and minimize algae growth).
3. Turn off fan.
4. Disconnect water and power to the unit.

**NOTE: If water is not disconnected, turn off the water hose whenever the PolarCool is not in use.**

## 6 Controls

PolarCool 18", 24", and 36" Variable Speed units feature a user friendly control panel interface with status indicator lights.

The PolarCool 48" Single Speed unit has a user friendly control panel interface (See Diagram 6B).

### 6.1 18", 24", and 36" Variable Speed Control Panel

See Diagram 6A for button and light locations.

**Power Indicator Light** – The red Power Indicator Light is located at the bottom-center of the control panel label and illuminates the Danger High Voltage Triangle. The Power Indicator Light remains ON CONSTANTLY while power is applied to the PolarCool unit.

**Fan Control ON/OFF Button** – This button is used to start and stop the fan.

+ **And – Speed Control Buttons** – Used to select the fan speed to any position between LO and HI. These buttons control the fan speed only and does not turn the fan on or off.

**Water Pump Control ON/OFF Button** – This button is used to start and stop the water pump.

**CAUTION: This switch should never be turned on unless there is water in the pan.**

**Pump ON** – The green Pump On Indicator Light is ON SOLID when the water pump is running.

**Low Water** – The red Low Water Indicator Light is ON BLINKING when the water level is low for less than 1 minute. After the first minute, the red Low Water Indicator Light is ON SOLID.

**Fill** – The green Fill Indicator Light turns ON BLINKING when the water level has remained low for a constant time of more than 1 minute. Also, after the first minute of constant low water level, the water pump will automatically turn off, the Pump ON and green Fill Indicator Lights will be ON BLINKING, and the red Low Water Indicator Light will be ON SOLID.

**NOTE: The water must be filled above the low level switch and remain above the switch for a minimum of 1 minute solid before the water pump will turn back On.**

Diagram 6A

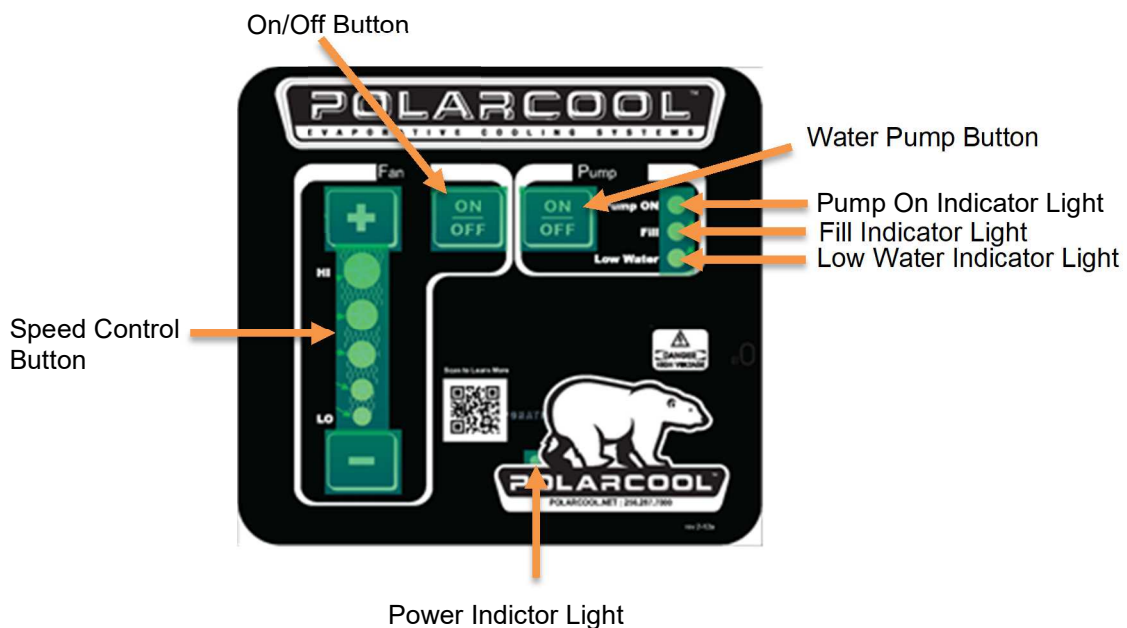

## 6.2 48" Single Speed Control Panel

See Diagram 6B for button and light locations.

**Fan Control ON/OFF Button** – This button is used to start and stop the fan.

**Pump Control Switch** – Used to start and stop the pump.

**CAUTION: This switch should never be turned on unless there is water in the pan.**

Diagram 6B

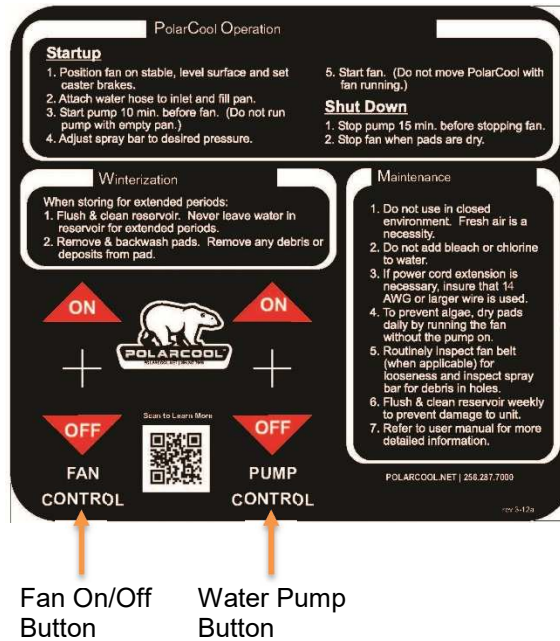

## 7 PolarCool Pad Care and Maintenance

### 7.1 Breaking in New Pads

When pads are new, their slick surface will prevent the fast water absorption that will happen with older pads. For this reason, it is important that the first time new pads are used, to allow the pump to run for two or three hours. This will "soak-in" the pads, and allow faster start-up later.

After soaking new pads, turn off the pump, fan, and water supply, unplug the unit, and drain the reservoir. This eliminates chemical residues that have washed out of the new pads.

Foaming can occur with new pads. If excessive foaming is experienced, repeat the procedure described above two or three times to flush chemical residues from the pads. Reducing the water flow to the pads may also be helpful to reduce foaming.

### 7.2 Frequency of Pad Replacement

PolarCool pads, produced from a cellulose base and impregnated with a plastic resin anti-rot agent, can give years of trouble free operation with proper maintenance (3 to 5 years is typical).

### 7.3 Extending Pad Life

As you use the PolarCool system, you will notice the need for good preventive maintenance. Algae growth, scale (hard crusty deposits), and dirt accumulation are typical problems associated with poor maintenance.

Maintaining the PolarCool is very simple. It only takes a small amount of time and effort. If you follow the guidelines in Sections 7, 8, and 9, your pads will last much longer, and be much more efficient.

### Algae

To prevent algae, allow the pads to dry out each day, by running the fan without the pump running until the pads are completely dry (about 15 minutes).

### Scale

Scale is a concentration of solids that “plate” the surface of the pads if the water contains too many impurities. Scale formation can be prevented by using water with a pH between 6 and 9 and silica levels below 150 ppm. If this is impractical, scale can be minimized by increasing the drain-off rate. To clean pads, spray pads frequently with water hose.

### Dirt and Dust

If the pads are allowed to get excessively dirty, they should be removed from the system and washed down with a water hose.

## 7.4 Cleaning or Replacing the Pads

### Diagram 7A

18" Pad Removal

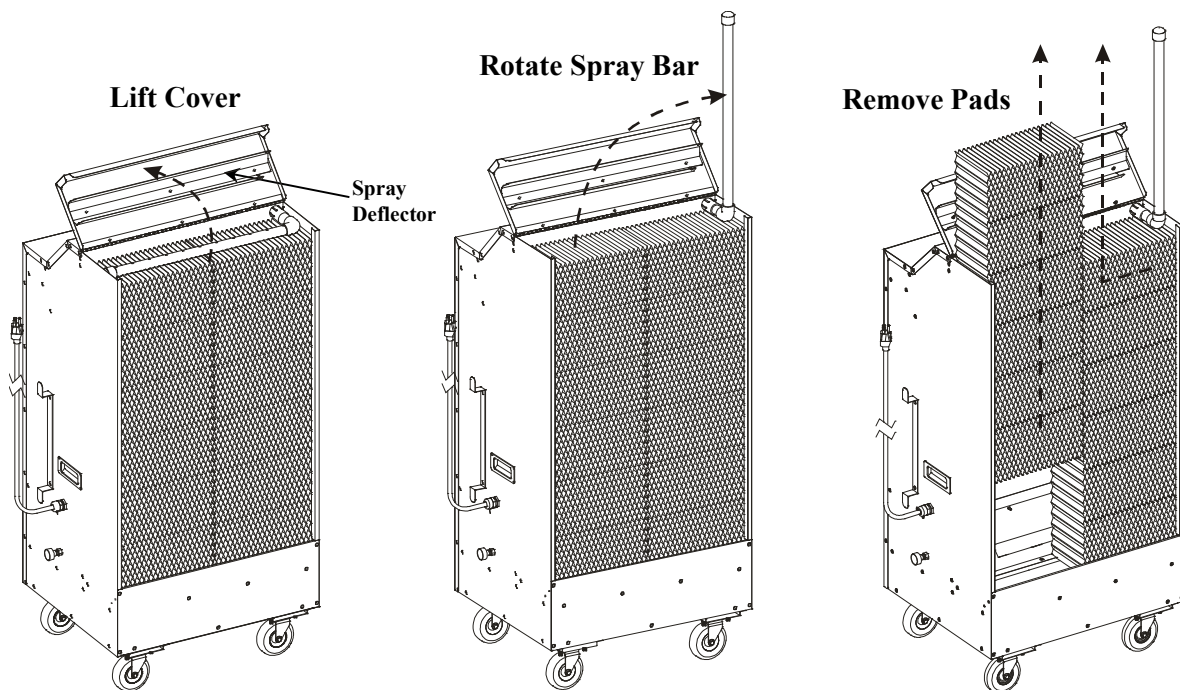

**NOTE: When lowering the cover, do not force the cover closed. Ensure the Spray Bar is correctly centered beneath the Spray Deflector.**

## 24", 36" and 48" Pad Removal

PolarCool shown with Cover Open  
And Pad Tilted Forward

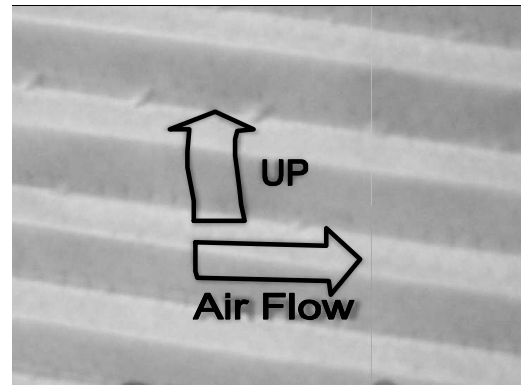

**Diagram 7B**

1. Disconnect all electrical power to the PolarCool unit.
2. Turn off the water source.
3. Lift cover and remove pads.
4. Hose down each side of pads.

**CAUTION: Do Not Use High Pressure Washer To Hose Down Pads!**

5. Drain the reservoir.
6. Clean out strainer.
7. Refill reservoir with clean water.
8. Replace pads. Look for the Air Flow Diagram on the side of the pad as shown in Diagram 7C.



**Diagram 7C**

**IMPORTANT: Install Pads into PolarCool with Air Flow in direction of arrow and with up arrow pointing UP.**

9. Turn on the pump to run fresh water over the pads for about 20 minutes. Use as much water as possible.
10. Gently hose stubborn deposits from the face of the pads.
11. Completely empty the reservoir to remove all the old algae and dirt that will rinse off the pads.
12. Refill with clean water.

**NOTE: When replacing the Pads, see Section 7.1 for more information on New Pad Break-In.**

## 8 Maintenance

Since evaporative coolers require maintenance, the PolarCool has been designed to make maintenance as easy as possible. By simply raising the rear cover, basically all critical parts are within easy reach for inspection, including the pads, spray bar, fan belt (48" model only), pump, strainer, and water reservoir.

## 8.1 Water Distribution (Spray Bar)

Maintaining even water distribution to the pads is the most important way of extending pad life. If an area of pad does not receive enough water, cooling efficiency will be degraded.

Dry spots or streaks on the Pads can also be caused by clogged holes in the spray bar. Investigate by raising the rear cover and running a pipe cleaner, or small dowel into the holes in the spray bar to clear any clogged holes. The spray bar end cap or caps may be removed for easier cleaning. Ensure the holes in the spray bar point upward during operation.

## 8.2 Flow Control Adjustment

Flow control adjustments are made at the Flow Control Valve as shown in Diagram 8A. Flow adjustments are factory preset, however can be adjusted by the user based upon local water pressure and evaporative conditions at the site. The amount of water flow affects the efficiency and operation of the PolarCool. During operation the flow should be adjusted so that sufficient water soaks the pads, but only enough to completely soak the pads.

If there is too much water flow, the pads become over-soaked, that is, there is more water flow than required for proper evaporation. Surplus water may be sucked into the fan producing a water droplet spray directly in front of the PolarCool. In some cases, if you stand in front of the PolarCool you may feel the water spray! The efficiency of the Polar cool is reduced in this case. If this happens, reduce the water flow.

If there is too little flow, there will not enough water to fully soak the pads. You can actually see dry spots in the pads. Again, this reduces the efficiency of the PolarCool. If this is the case, increase the flow until the pads become fully soaked.

Adjust the Water Flow as described above. The FULL OPEN and CLOSED positions of the Valve are shown in Diagram 8B.

**Diagram 8A**

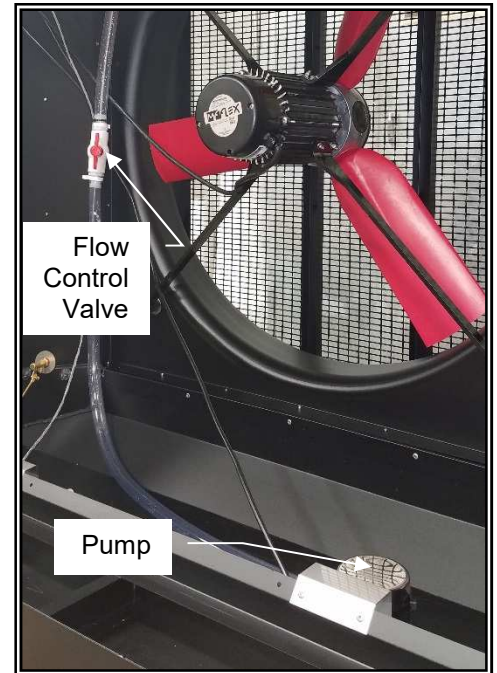

**NOTE: The 48" Model has a Flow Adjustment Valve on the exterior of the unit. It can be identified by the red, circular knob.**

**Diagram 8B**  
**Flow Control Valve Adjustment**

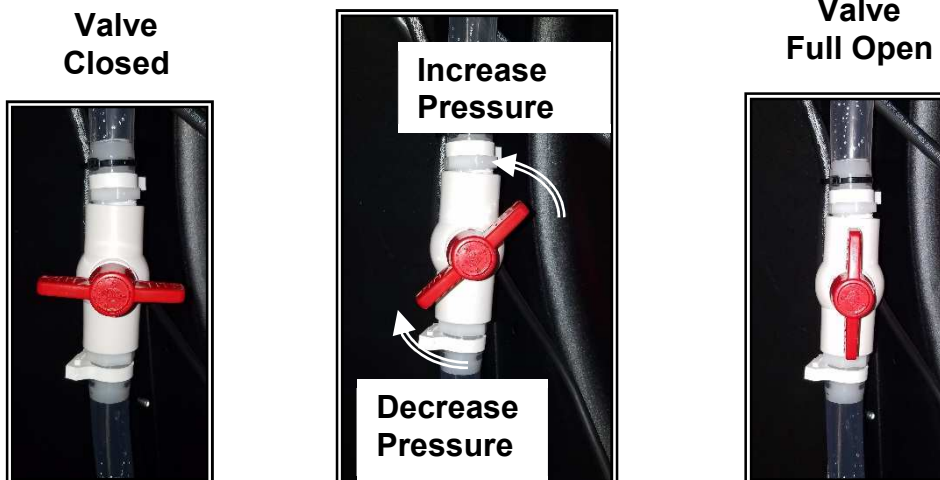



### 8.3 Float Adjustment

**NOTE: The Float Is Preset By Manufacturer And Should Not Require Adjustment Under Normal Circumstances!**

If adjustment is required, perform the following steps:

1. Disconnect all electrical power to the PolarCool unit.
2. Carefully remove pads.
3. Locate Float Valve inside PolarCool. Refer to Replacement Parts Diagram.
4. Loosen adjustment screw as shown in figure at right.
5. To decrease water level in reservoir, move float arm downward as shown. Retighten adjustment screw.
6. To increase water level in reservoir, move float arm upward as shown. Retighten adjustment screw.
7. Replace pads.
8. Return PolarCool to operation.

Repeat steps 1 thru 7 above as required for proper adjustment of water level.

**NOTE: Water level in reservoir is normally 2-1/4" ± 1". Do not allow the reservoir water to contact the pads when the reservoir water level is at the highest point.**

9. After adjusting water level, return PolarCool to service.

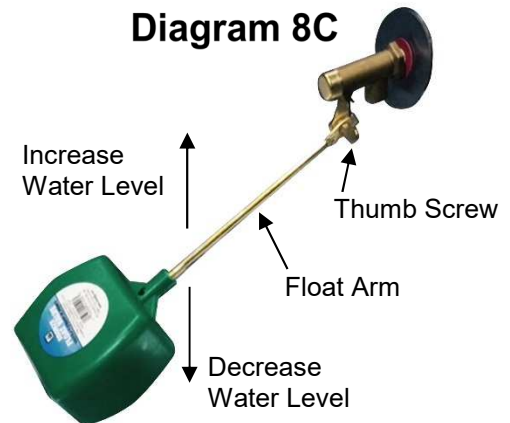

### 8.4 Flushing the Reservoir

The pads and the complete water system should be flushed out at least once a week and the reservoir wiped clean.

1. Disconnect all electrical power to the PolarCool unit.
2. Turn off the water source.
3. Drain the reservoir. The reservoir can be drained using the Drain Outlet for 18", 24" and 36" models, or the Discharge Valve and Pump for 48" models.

**NOTE: If desired, an optional customer supplied drain hose and cut-off valve can be attached to the drain pan outlet beneath the PolarCool.**

4. Wipe out the reservoir.

**NOTE: Do not allow the pump to run without water in the reservoir. Without water, the pump may be damaged.**

4. Restore the water source and fill the reservoir.
5. Run the pump for at least 15 minutes.
6. Drain the reservoir out again and refill with fresh water.
7. Start the pump and fan.



## 8.5 Cleaning the Pump Filter

The water pump includes a removable plastic filter on the bottom of the pump which should be cleaned weekly when the reservoir is flushed.

1. Disconnect all electrical power to the PolarCool unit.
2. Turn off the water source.
3. Remove the pump from the reservoir, remove and clean the screen on the bottom of the motor, and reinstall the pump in the same location and method as removed.

**NOTE: Do not allow the pump to run without water in the reservoir. Without water, the pump may be damaged.**

4. Restore the water source and fill the reservoir.
5. Reconnect power and run the pump for at least 15 minutes.
6. Turn the fan ON.

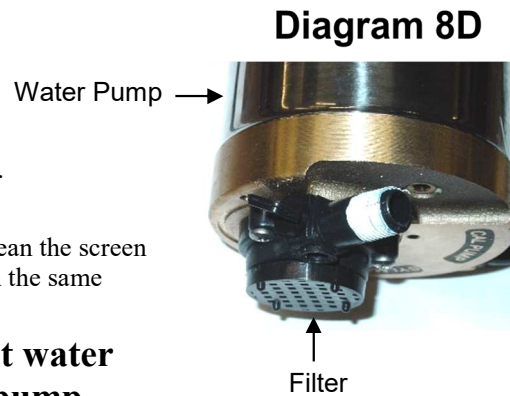

## 8.6 Why Drain Water from the System?

If you have ever left a pot of coffee warming on the coffee maker you know the two principles at work in evaporative cooling systems. First, as the coffee sits on the warming plate, the level of water in the pot goes down. Second, the remaining coffee gets stronger as the water evaporates.

In your cooling system, these effects still apply. As water evaporates, no impurities are carried along. This leaves all sorts of minerals, chemicals, and other impurities behind. The concentration of impurities in the reservoir and system will quickly rise.

Drain the reservoir daily in dusty conditions, and twice a week in clean air. See Section 8.4.

## 8.7 Belt Inspection or Removal (48" Model Only)

**NOTE: Experience indicates that drive tension should be checked between 1/2 hour and 24 hours running at full load. A re-tension may be necessary depending on the application. Any initial belt stretch is then taken up. Subsequently, belt tension should be checked periodically and adjusted when necessary.**

1. Disconnect all electrical power to the PolarCool unit.
2. Remove pads.
3. TEST BELT TENSION: Press on belt with finger about halfway between pulleys. Belt should deflect about 3/4" if correctly fitted.

TO REMOVE BELT:

4. Slowly rotate belt while carefully rolling belt off of prop pulley.
5. After removing belt, turn belt inside out. Links should resemble Diagram 8E.
6. Flex belt to form a short, tight loop at one end.

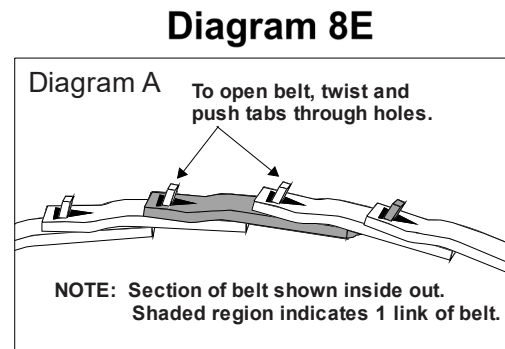

7. Twist and unlock tabs holding link. This will open belt.
8. Remove links as required to tighten belt.
9. After removing link(s), reattach belt together by locking tabs through holes.
10. Turn belt to place tabs to inside of belt.
11. Hook belt onto motor pulley. Roll belt onto Prop pulley.
12. After belt is installed, repeat Step 3: TEST BELT TENSION.

**NOTE: Make sure arrows on belt are pointing in direction of prop rotation.**

## 8.8 Winterization

When storing for extended periods:

1. Flush and clean reservoir. Never leave water in reservoir for extended periods.
2. Remove and backwash pads. Remove any debris or deposits from pad.
3. Remove the drain outlet cap to prevent water accumulation inside the reservoir.

## 9 Preventive Maintenance Requirements

- Flush the system at least once per week and wipe the reservoir clean to prevent damage to the unit. Refer to Section 8.4.
- Allow the pads to dry out each day, by running the fan without the pump running until the pads are completely dry (about 15 minutes).
- Drain the system during extended shutdowns.
- Disinfect the whole system once per quarter.
- Routinely inspect fan belt (48" model only) for looseness and inspect spray bar for debris in holes.
- Turn off water hose to PolarCool whenever the unit is not in use.
- Have the right amount of water running over the pad.
- If power cord extension is necessary, ensure that you use 12 AWG or larger wire.
- Ensure that air is not limited or restricted from entering or exiting the unit.
- Identify and correct leaks in the system.
- Excessive dust, fumes, and harsh cleaners, should be avoided.
- Do not use in closed environment. Fresh air is necessity.
- Do not add chlorine or bleach to water.
- Never use phosphate based water treatment chemicals.
- **NOTE: After running 30 minutes to 24 hours at full load, inspect belt tension (48" model only). Refer to Section 8.7 Belt Inspection or Removal.**

## 10 Troubleshooting Guide

<b>Problem</b>	<b>Check/Action</b>	<b>Reference Section</b>
Swivel casters will not turn.	Check installation of caster hardware. Hardware must be in the proper order and location.	4.1
First time using a NEW PolarCool - Water overflows	Remove tape from float.	4.2
Water is splashing off of pads	Pads may be in backwards; Check Flow chart on side of pad.	Diagram 4D
Water spraying out from cover.	Ensure the holes in the spray bar point upward into the spray deflector. (Vertical Spray).	8.1
Water is not spraying out of ANY spray bar holes.	Ensure pump switch is ON; Check for sufficient water in reservoir; Check screen on bottom of pump for obstructions.	6, 8.3, 8.5
Water is not spraying out of SOME spray bar holes.  Excessive dry streaks in the pads.	Adjust spray using the Flow Control Adjustment Valve, the spray bar should be cleaned, OR the pump screen should be cleaned.  Remove spray bar and clean the bar and all holes.	8.2 8.1 8.5
Water overflows	Adjust float valve to a lower position.	8.3
Fan motor doesn't turn ON and no sound from the motor.	Check PolarCool Switches, power cord, GFCI outlet, and circuit breaker.	
48" Fan blade doesn't turn or slips.	Check for broken or loose fan belt. (48" ONLY)	8.7
Motor overheats and shuts off then restarts minutes later.	Extension cord gauge is too small or the air passage is blocked or partially obstructed.	
Pump does not work.	Check for low water-level and low-level switch. (18", 24" and 36" Variable-Speed models)	4.2

## 11 Replacement Parts List

Part	Volts/Hz	18" Vari Spd	24" Vari Spd	36" Vari Spd	48" Sgle Spd
<b>Cooling Pads</b>		0050-6503	0050-6502	0050-6501	0050-6500
<b>Complete Pad Set</b>		2 Required	3 Required	5 Required	6 Required
<b>Water Pump</b>	120v / 60Hz	6422-0640	6422-0645	6422-0645	N/A
	230v / 60Hz	N/A	N/A	N/A	6422-0647
<b>Fan Motor</b>	120v / 60Hz	3017-0050	3017-0050	3017-5600	N/A
	230v / 60Hz	N/A	N/A	N/A	3017-3080
<b>Fan Belt</b>		N/A	N/A	N/A	1022-2998 (55-1/2") (141 cm)
<b>Fan Prop</b>		6403-5611	6403-5612	6403-5600	6403-5014
<b>Float Valve</b>		1009-0107	1009-0107	1009-0107	1009-0107
<b>Fan Switch</b>		N/A	N/A	N/A	3001-2865
<b>Front Mesh Guard</b>		0011-7100	0011-7005	0011-7007	0011-7006
<b>Spray Bar</b>		6422-0570	6422-0532	6422-0531	6422-0530
<b>Pulley (motor)</b>	230v / 60Hz	N/A	N/A	N/A	1011-2650
<b>Pulley (Fan Prop)</b>		N/A	N/A	N/A	1011-0100
<b>Bearing Assy.</b>		N/A	N/A	N/A	1016-0100
<b>Hose Adapter Fitting</b>		1021-3000	1021-3000	1021-3000	1021-3000
<b>Fan Shaft</b>		N/A	N/A	N/A	0411-14099
<b>Pump Switch</b>		N/A	N/A	N/A	3001-2865
<b>Low Level Switch/Harness</b>		3001-0050	3001-0050	3001-0050	N/A
<b>PCB189 Circuit Board</b>	120v / 60Hz	6450-6058	6450-6059	6405-6060	N/A
<b>Control Box Seal</b>		1028-3500	1028-3500	1028-3500	N/A
<b>Level Switch</b>		3001-0050	3001-0050	3001-0050	N/A
<b>Nut</b>		1001-0110	1001-0110	1001-0110	N/A

# 12 Replacement Parts for Direct Drive – Variable Speed 18" PolarCool

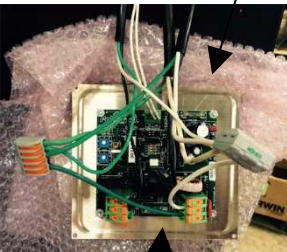
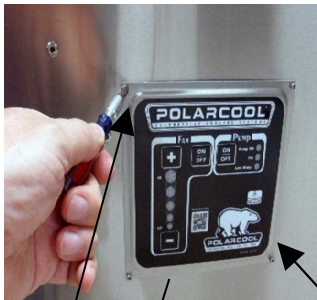
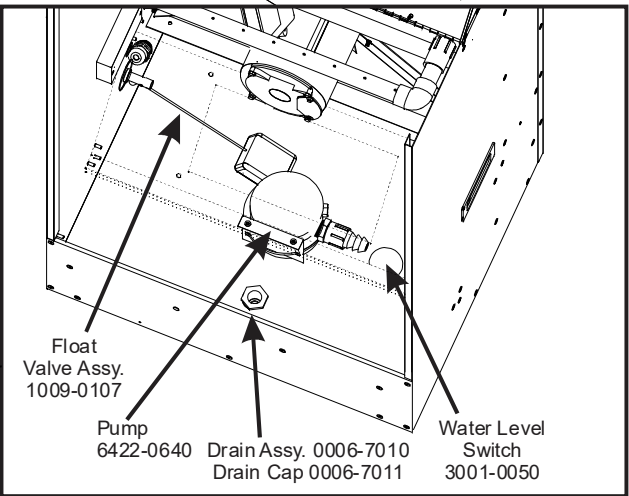
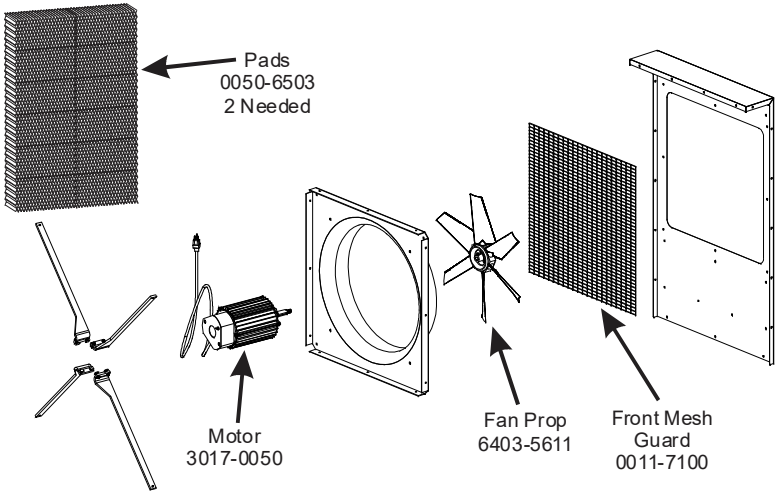

Allen Wrench (Not Provided)

Control Board Replacement Kit 6450-6058

Control Cover

Pads 0050-6503 2 Needed

Motor 3017-0050

Fan Prop 6403-5611

Front Mesh Guard 0011-7100

Float Valve Assy. 1009-0107

Pump 6422-0640

Drain Assy. 0006-7010  
Drain Cap 0006-7011

Water Level Switch 3001-0050

# 13 Replacement Parts for Direct Drive – Variable Speed 24" PolarCool

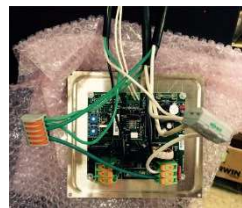
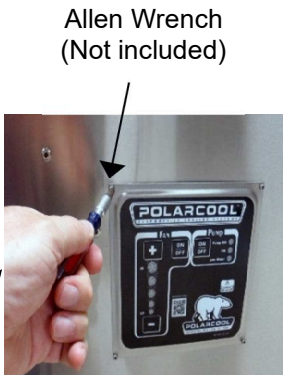
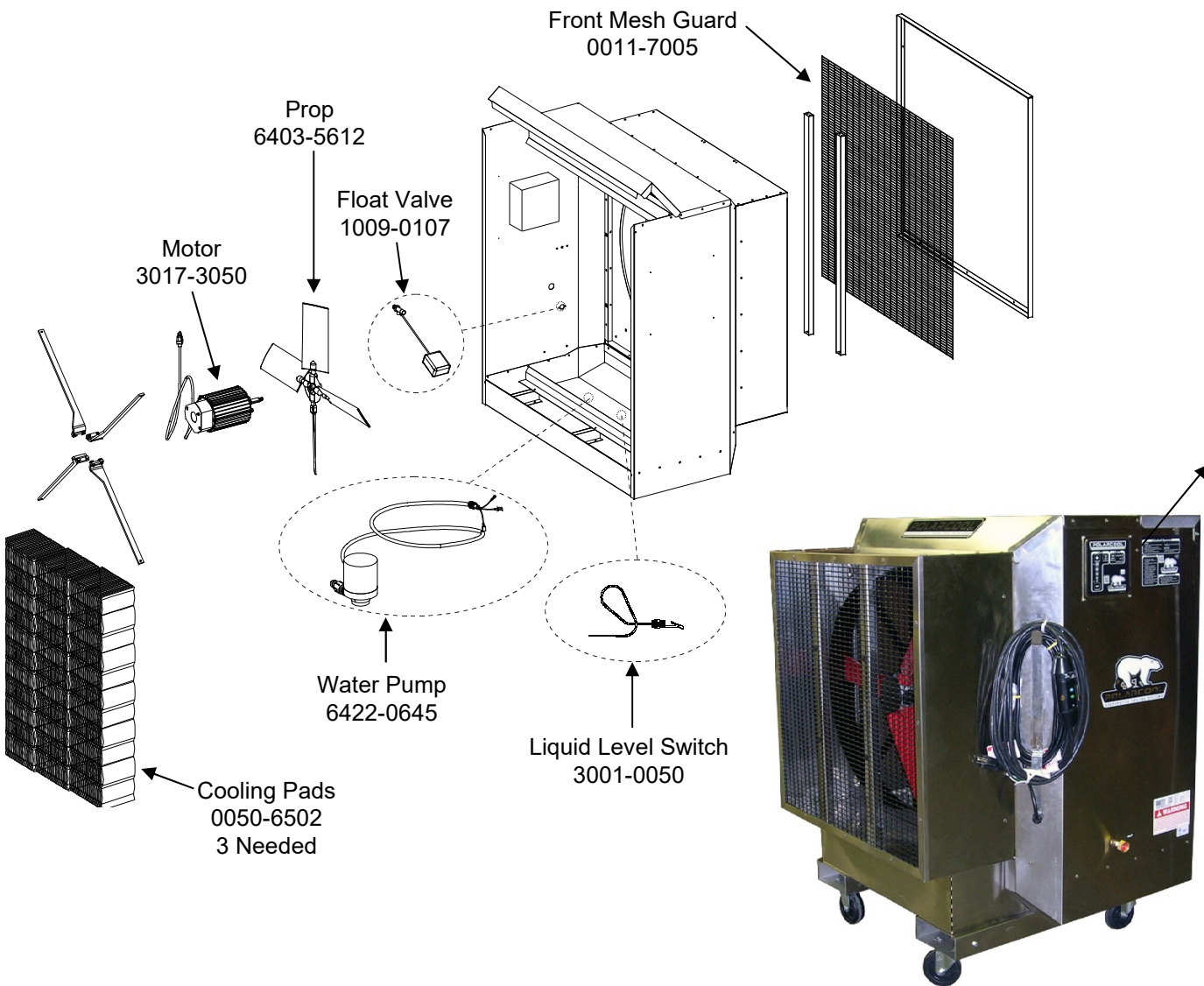



# 14 Replacement Parts for Direct Drive Variable Speed 36" PolarCool

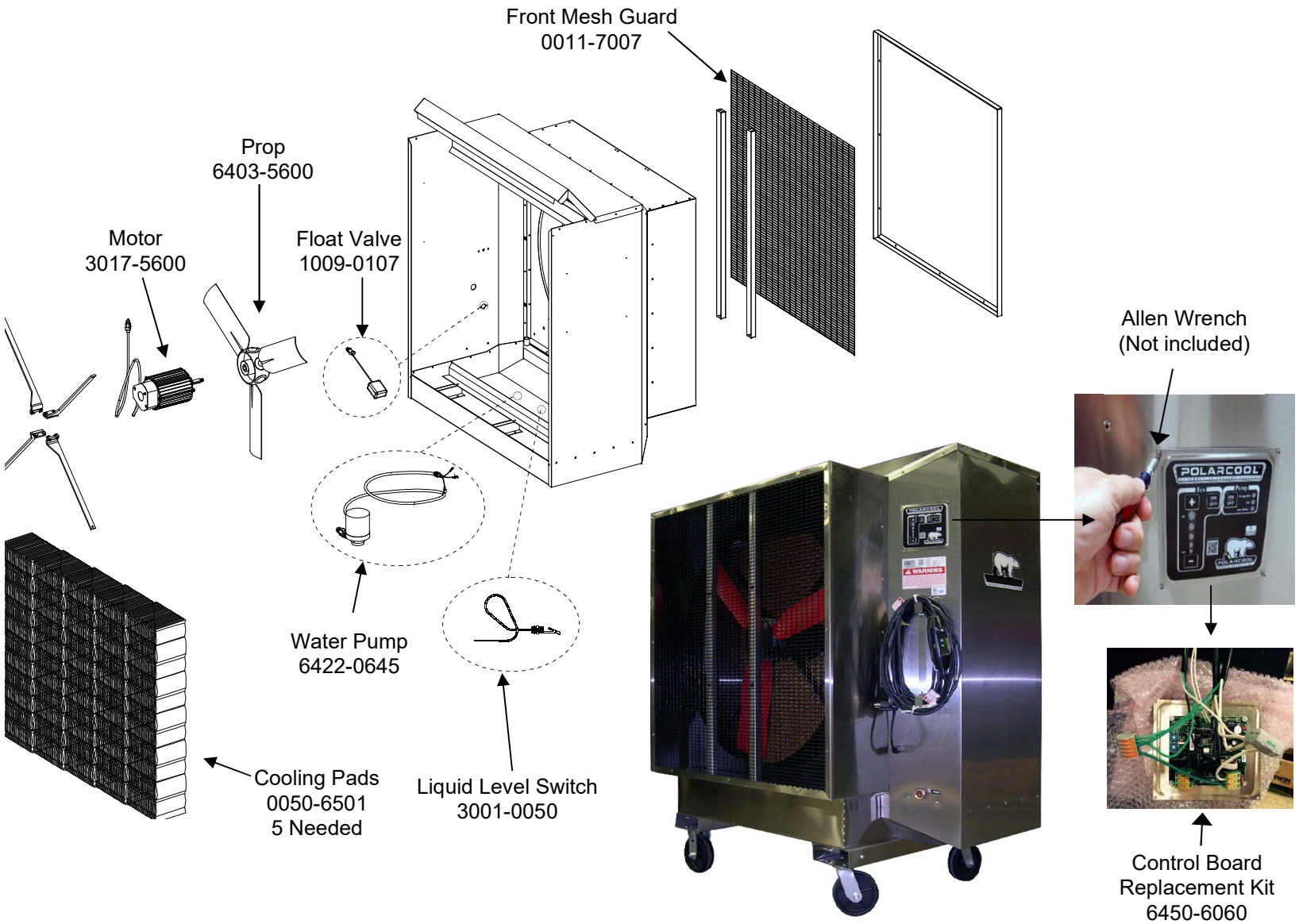



# 15 Replacement Parts for Belt Drive – Single Speed 48" PolarCool

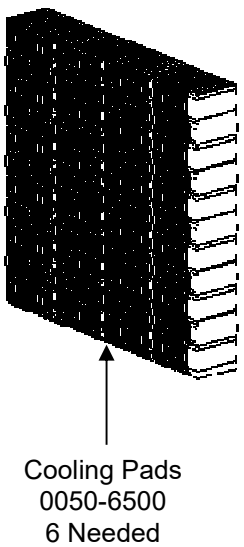
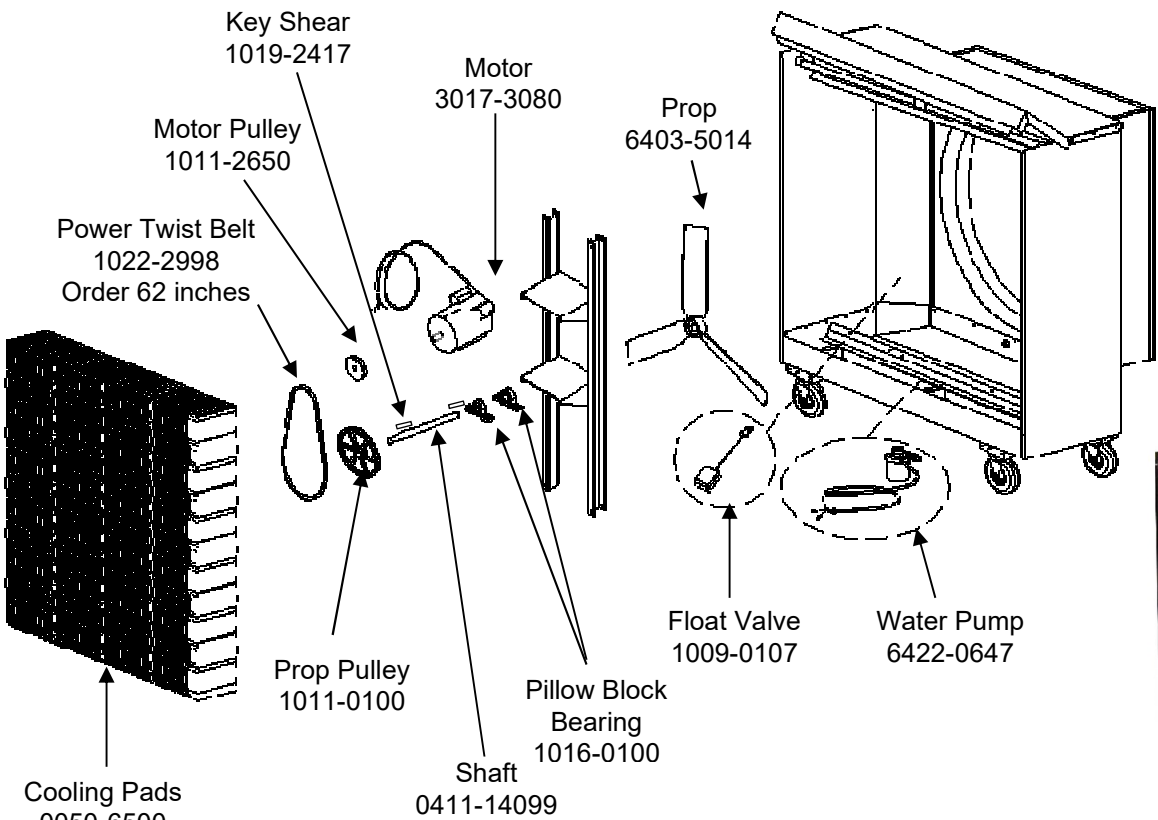
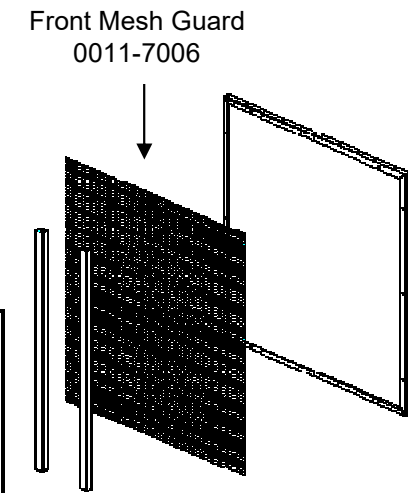

# 16 PolarCool Wiring

18", 24", and 36" Models

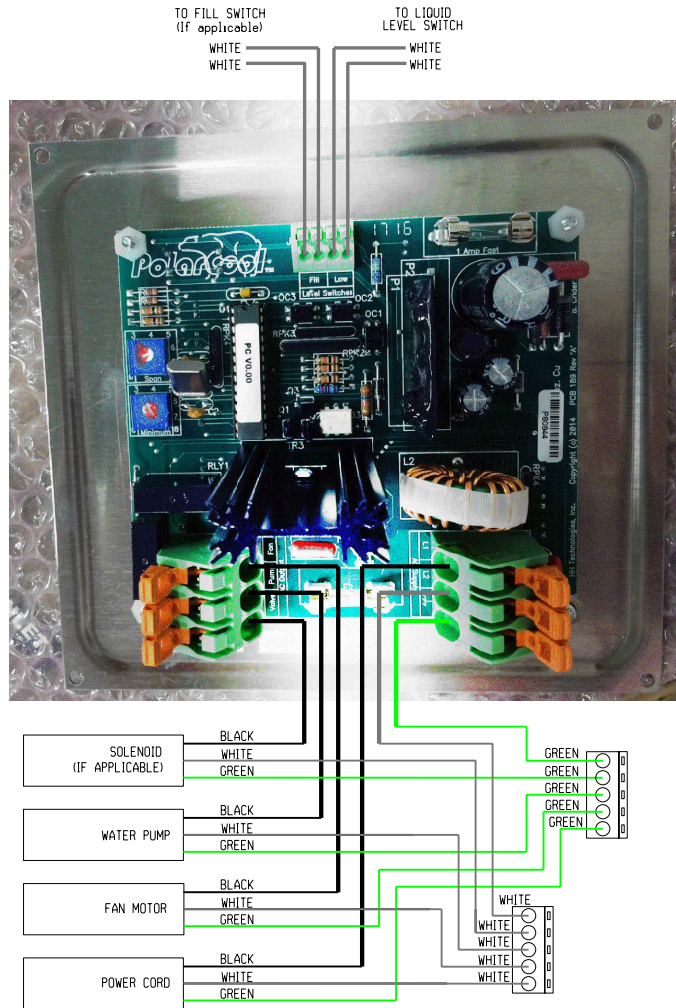

48" Model

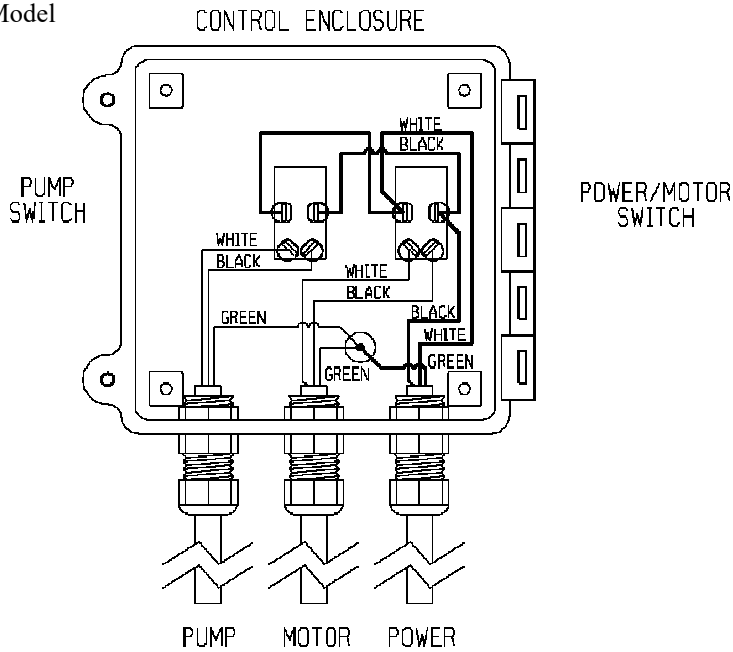



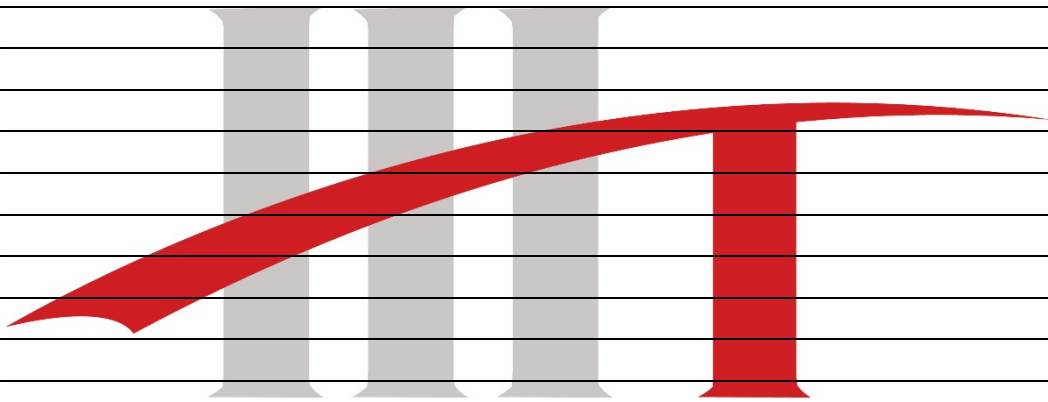

HH TECHNOLOGIES